

WASTE X PRESS®

food waste reduction system

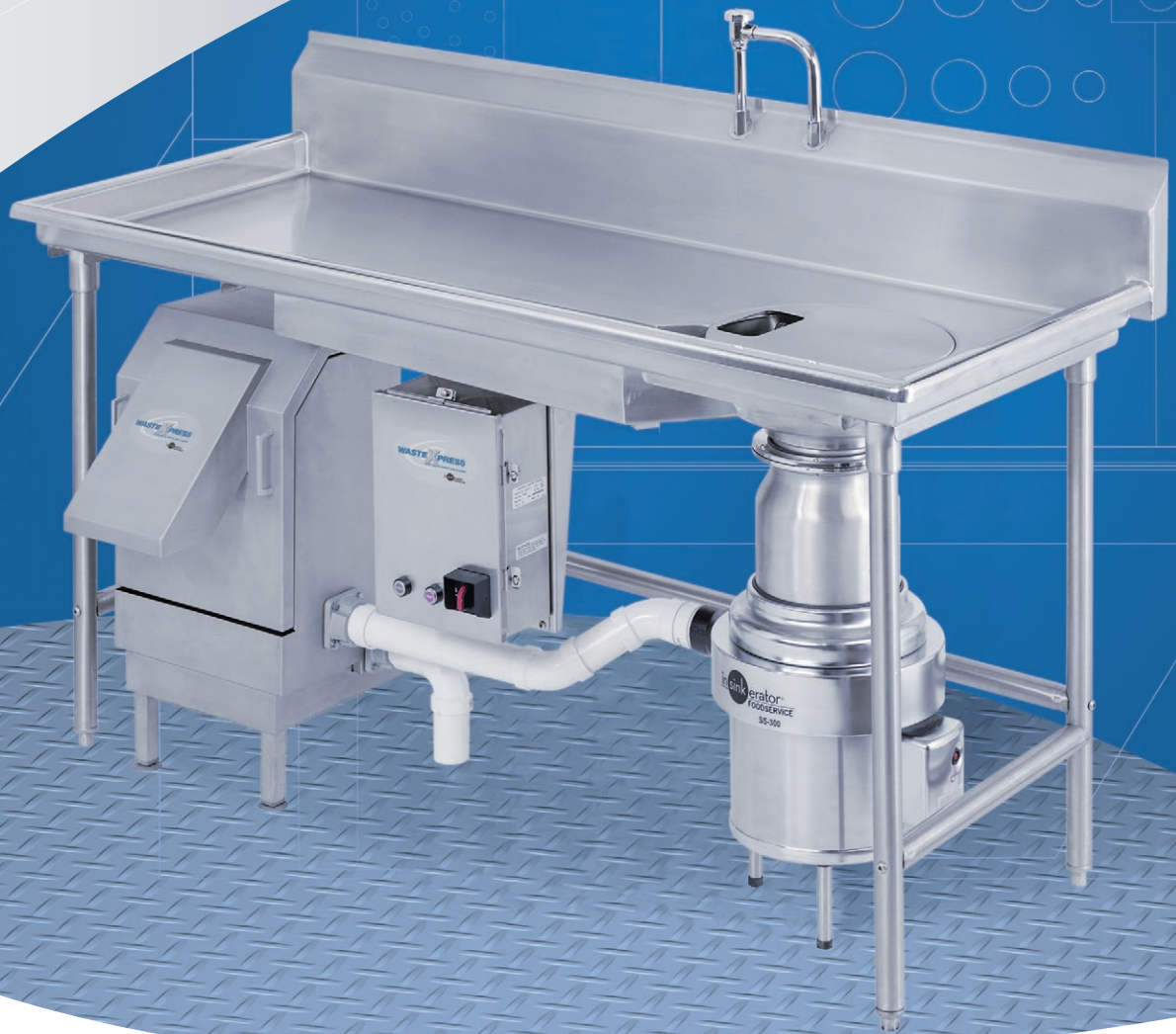

The most trusted name in food waste management

in sink erator®
FOODSERVICE



r e d u c e

food waste reduction system

For more than 70 years, we have been helping food service operations efficiently manage waste disposal.

That commitment continues with the Waste Xpress® high-performance waste reduction system.



Improved Productivity

The Waste Xpress system processes both liquid and solid waste, saving kitchen staff time on waste separation and trips to the dumpster. They can perform more productive tasks in a cleaner environment.

Cleaning and maintenance are quick and easy. Auger, auger screen and chute remove easily for cleaning, without the use of tools.

How the System Works

The disposer grinds kitchen waste, which is then sent to the dewatering section where water is squeezed out. Solid waste is reduced by 85% of its original volume. It can process up to 700 lbs. per hour.

The Waste Xpress system is the perfect choice where space is at a premium.

No Cardboard Required

To work properly, most pulpers require the use of cardboard. That can be a big problem for operations that don't use cardboard or where environmental regulations require recycling of cardboard.

Our system is designed to work without cardboard. It efficiently processes any and all of the wastes normally found in food service operations, including food scraps, paper place mats, napkins, sugar or jelly packets, milk cartons and drinking straws. A ratio of 50% food to 50% non-food waste is recommended for optimum performance.

Stainless Steel Construction

Our Waste Xpress system gives you InSinkErator® quality, performance and reliability.

- 3 HP disposer
- Easy to clean, no tools required
- Minimum water required

schools

restaurants

correctional facilities



nursing homes

universities

hospitals

WASTE X PRESS®

e waste by 85%

Environmentally Friendly

Food waste disposers are generally considered the safest, easiest and most environmentally sound method of eliminating biodegradable food waste. Some municipalities even require disposers.

However, other municipalities have outdated waste water handling and treatment plant facilities. Food service establishments in these areas would benefit greatly from the InSinkErator® Waste Xpress® system.

Our Waste Xpress system reduces bulk waste volume and turn ten bags of waste into less than two. So there's less to haul away and less to pay the waste haulers. And the finely ground, semi-dry pulp breaks down quickly in landfills.

Waste Xpress System

Can be installed under any standard dish table.

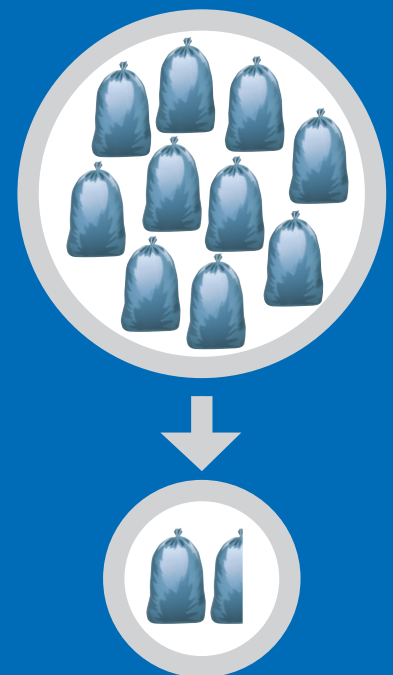
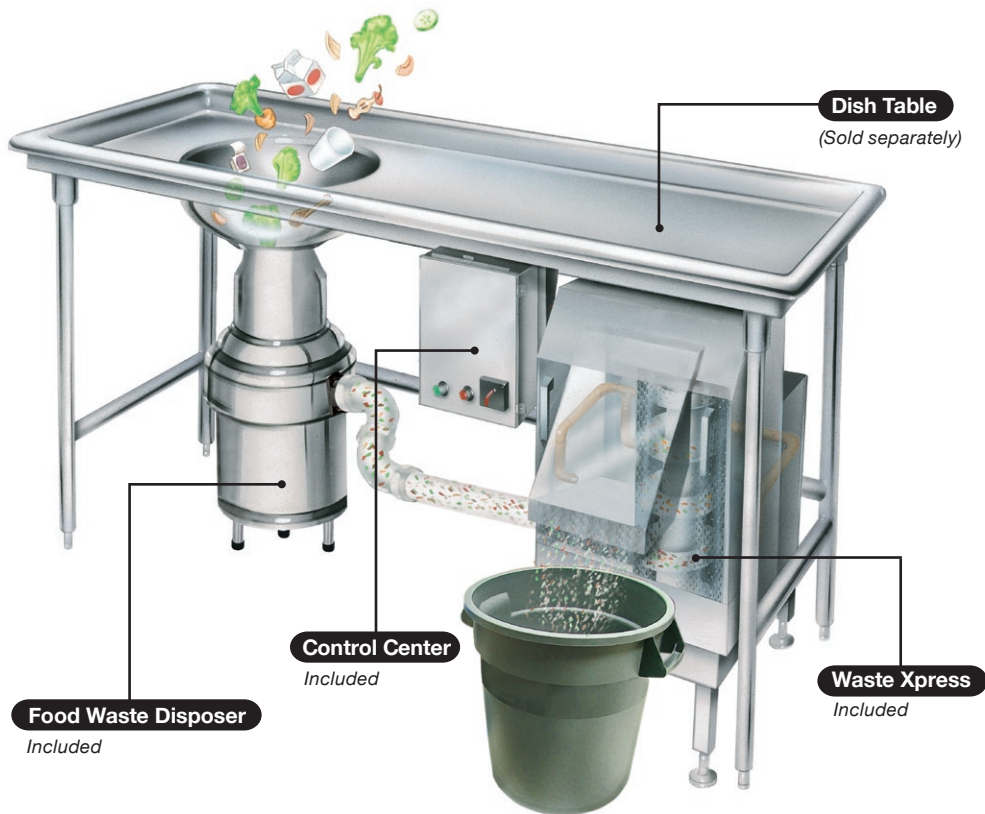

Typical Installation

Dish table, plumbing and electrical connections sold separately.

Sink Bowl

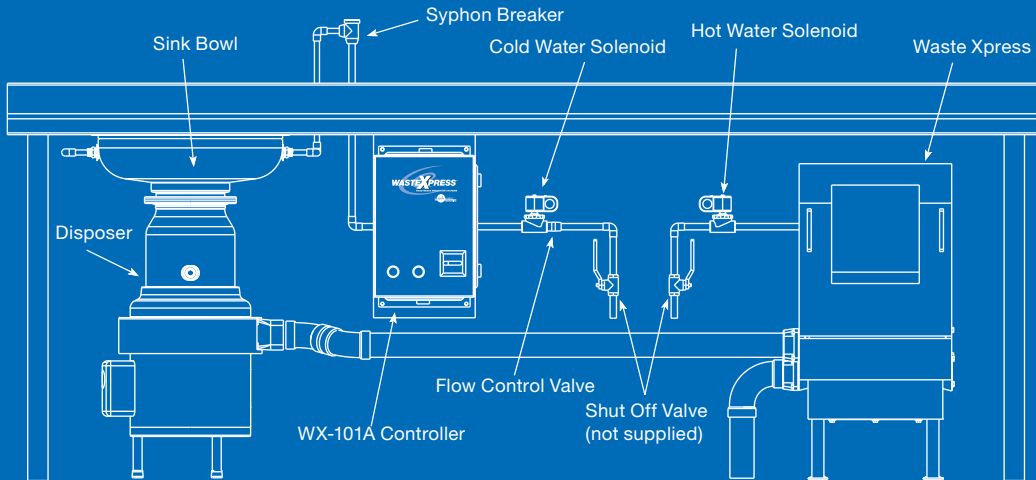

Trough

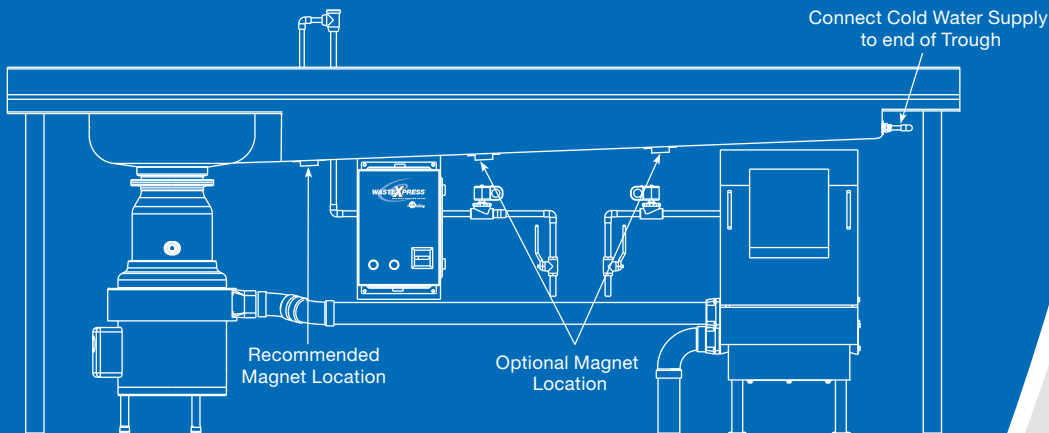

A trusted name

For overall quality, reliability and service, InSinkErator® has been the No. 1 choice of food service consultants and equipment dealers for 17 consecutive years.

Our waste reduction systems give you the same long-life construction, performance and dependability that make InSinkErator America's best-selling food waste disposer.

Count on the industry's most complete service network.

You're assured of prompt, expert service from over 300 factory-authorized InSinkErator service centers nationwide.

One-year on-site warranty on parts and labor.

For more information, call toll free **1.800.845.8345** or visit our website www.insinkerator.com/foodservice



1.800.845.8345
www.insinkerator.com/foodservice

The Emerson logo is a trademark and servicemark of Emerson Electric Co. InSinkErator® may make improvements and/or changes in the specifications at any time, in its sole discretion, without notice or obligation and further reserves the right to change or discontinue models.

© 2008 InSinkErator, a division of Emerson Electric Co. All Rights Reserved.